

DAWN

Enterprises

Specification Sheet

PC48S: 48" x 48" x 36" Square Concrete Planter

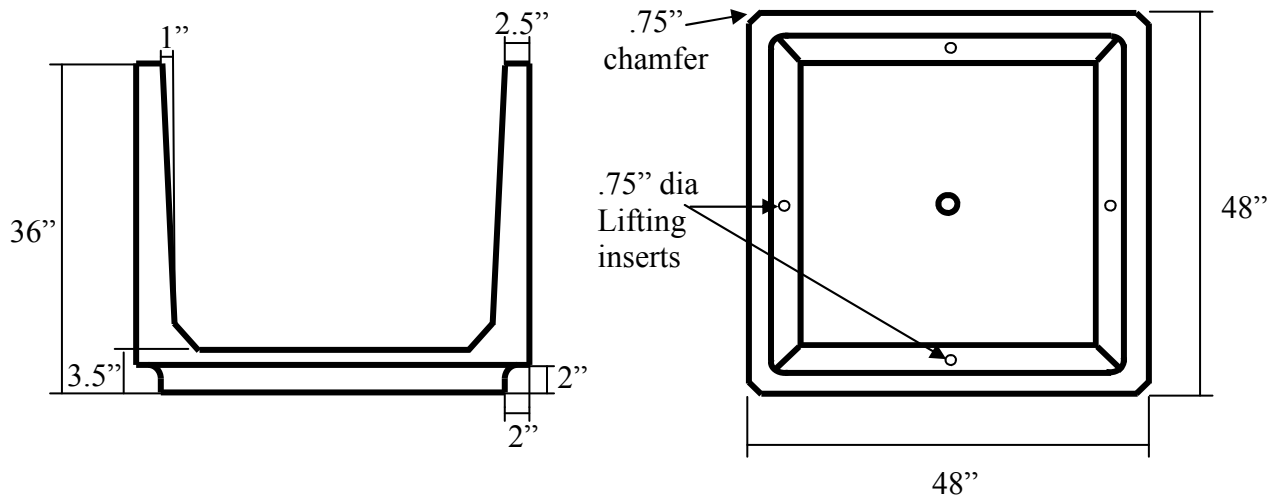

Specifications:

- Dimensions: 48" x 48" x 36" with 2.5" wall thickness at top.
- Weight: 2250 lbs
- Materials: 3/8" steel rebar, Type III Portland cement conforming to ASTM C150. All aggregate conforming to ASTM C33. All Steel Rebar conforming to ASTM – A 615. Due to the natural air entraining properties of Portland Type III cement, additional air entraining agents are not required. Air void content naturally occurring in a Type III Portland Cement mixture conforms to ASTM C457.
- Stress Load: 5000 PSI at 28 days
- Color/Finish: Please reference our color/finish chart for standard options.
- Warranty: One year warranty against manufacturer's defects