

# DAWN

## Enterprises

### RCG35S: 35 Gal Square Receptacle with Recycled Glass Spec Sheet

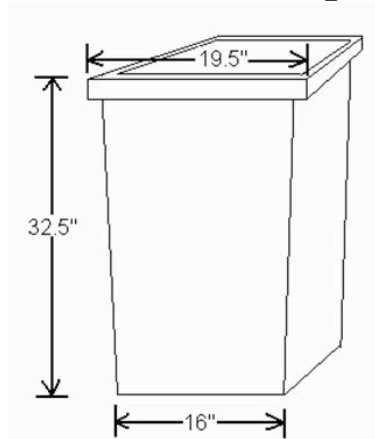

- Dimensions: 19.5" x 19.5" at top, 16" x 16" at base, 32.5" height
- Weight: 265 lbs
- Materials: 3/8" steel rebar, Type 3 Portland cement conforming to ASTM C31 specifications, Recycled Glass.
- Stress Load: 5000 PSI at 28 days
- Recycled Glass Color Options: Clear, Blue, Green, Citrus
- Concrete Color Options: Natural, Brown #238, Charcoal #920, White\* (\*additional charges apply)
- Finish: Optional Light Sandblast
- Warranty: One year warranty against manufacturer's defects